



Bio-Modeling Systems

The R&D booster for life sciences discoveries
A leading Integrative Systems Biology Company

Short Presentation

The full presentation is available on www.bmsystems.net

Bio-Modeling Systems SAS

Dr. François Iris (PhD), Chairman & CSO
Manuel Gea, Chief Executive Officer
Paul-Henri Lampe CIO Integration Systems Director
Dr. Gérard Dine (MD, PhD), Chief Medical Officer

To contact us

Bio-Modeling Systems SAS
26, rue Saint Lambert
75015 PARIS, FRANCE
e-mail: manuel.gea@bmsystems.net
web site: www.bmsystems.net



SUMMARY

1	BMSystems at a glance
2	CADI™ rational

BMSystems' Mission

BMSystems is a research-based biotech company that creates CADI*™ models to boost its clients/partners R&D programs with immediate applications generating highly attractive businesses

BMSystems research/business model:

- BMSystems generates *innovative hypotheses* to create new knowledge from raw information through the construction of CADI™ models and,
- BMSystems generates *real & attractive business* from this new knowledge through its innovative business model.

**Computer Assisted Deductive Integration*

BMSystems CADI™ models

The CADI™ models are detailed maps of inter-cellular and/or intra-cellular mechanisms associated with a biological status.

- CADI™ models are outstanding “non-mathematical” descriptive in-silico answers to explain the non-linear mechanisms of life and diseases.
- CADI™ models can describe the dynamics of pathological processes and/or pathological mechanisms vs. control.
- CADI™ models describe the mechanisms that cause the diseases, not only the consequences.
- CADI™ models create the optimum new knowledge required to identify/explain mechanisms that can lead to direct industrial applications.
- CADI™ models have repeatedly led to novel patentable discoveries in highly competitive applications.

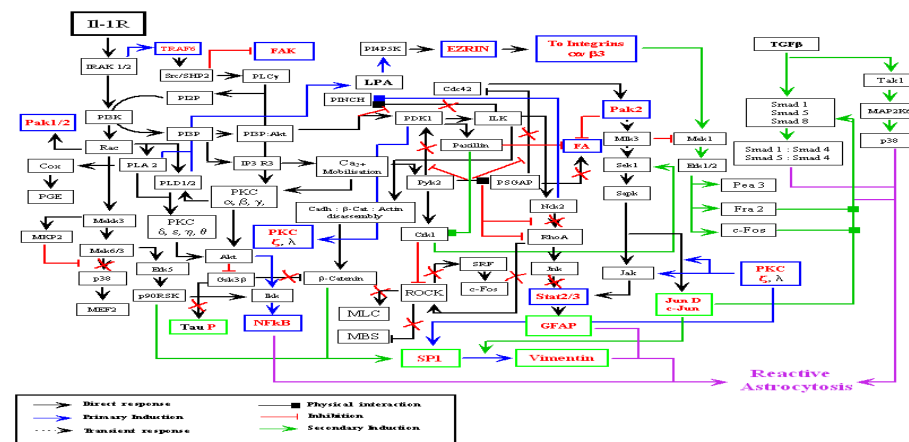

BMSystems profile

Corporate Profile:

- Bio-Modeling Systems or BMSystems S.A.S.
- Date of incorporation: 2004, registered in Paris.
- “Young innovative Company” status since creation.
- BMSystems is an Independent Private Company,
- BMSystems is *100% owned by its founders* (no search for external investors).
- BMSystems is member of *BiO* (USA)
- BMSystems is member of *the R&D committee* of Medicen life science world cluster.
- BMSystems controls 40% of its operational and funded spin-off: *Pherecydes-Pharma*.

Company specificities:

- BMSystems is a *“biology” driven company* that intensively uses I.T. resources.
- The company policy is to externalize all non-strategic functions and know-how.
- Number of FTE*: 9 scientists/professionals
- More than *100 professionals are* working on BMSystems’ related programs.
- CADI™, based on the *“negative selection process”*, was invented by Dr. François Iris (founder & CSO).
- The company’s proprietary technologies and methodologies *are industrial secrets*.
- BMSystems uses its CADI™ tools for its own research programs.

BMSystems outputs

What can we do with CADI™ models?

*Reduce time to result, improve success rate and reduce development costs in the following markets, **biomedical, chemistry, environment, energy**, through:*

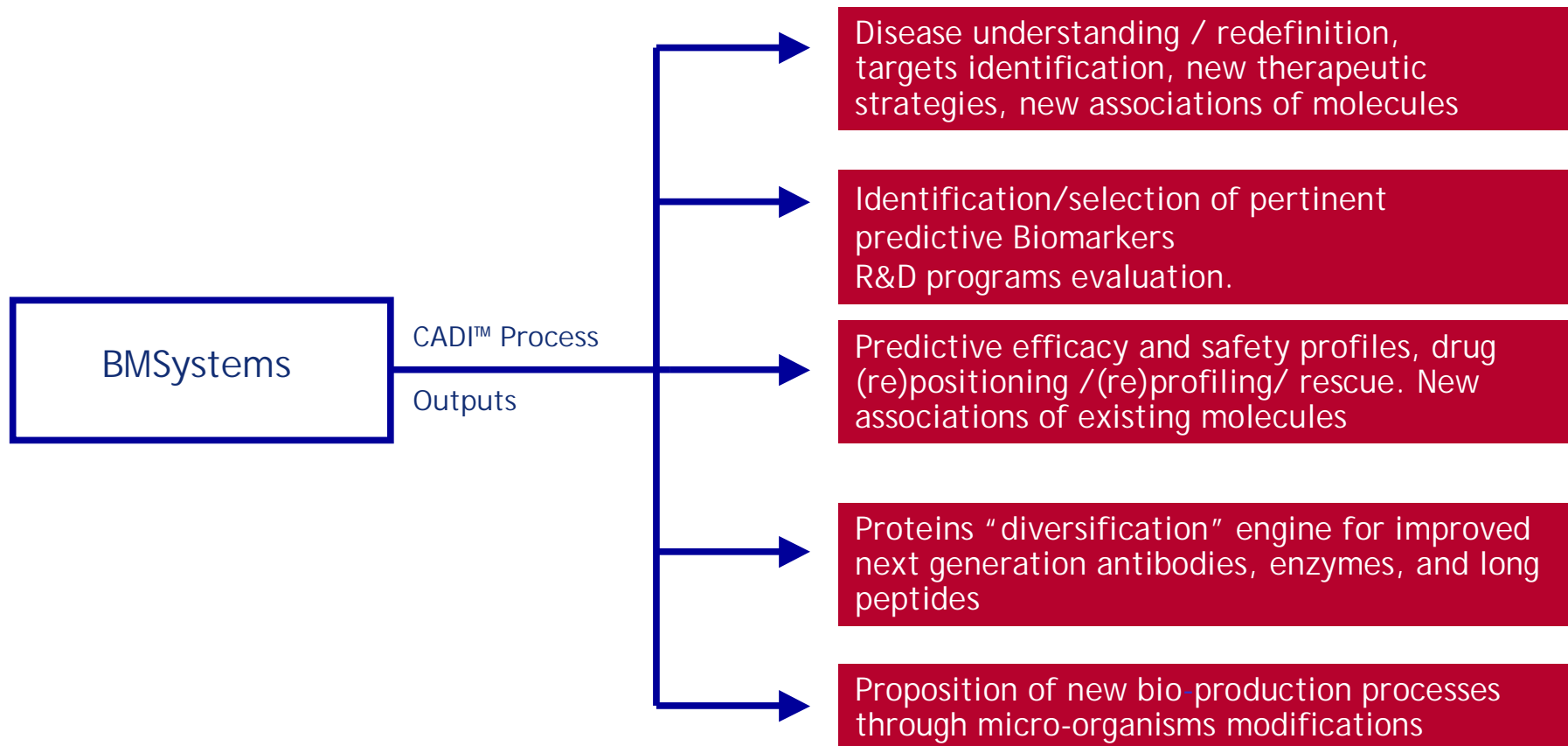

BMSystems business model

What kind of "Value" can we generate?

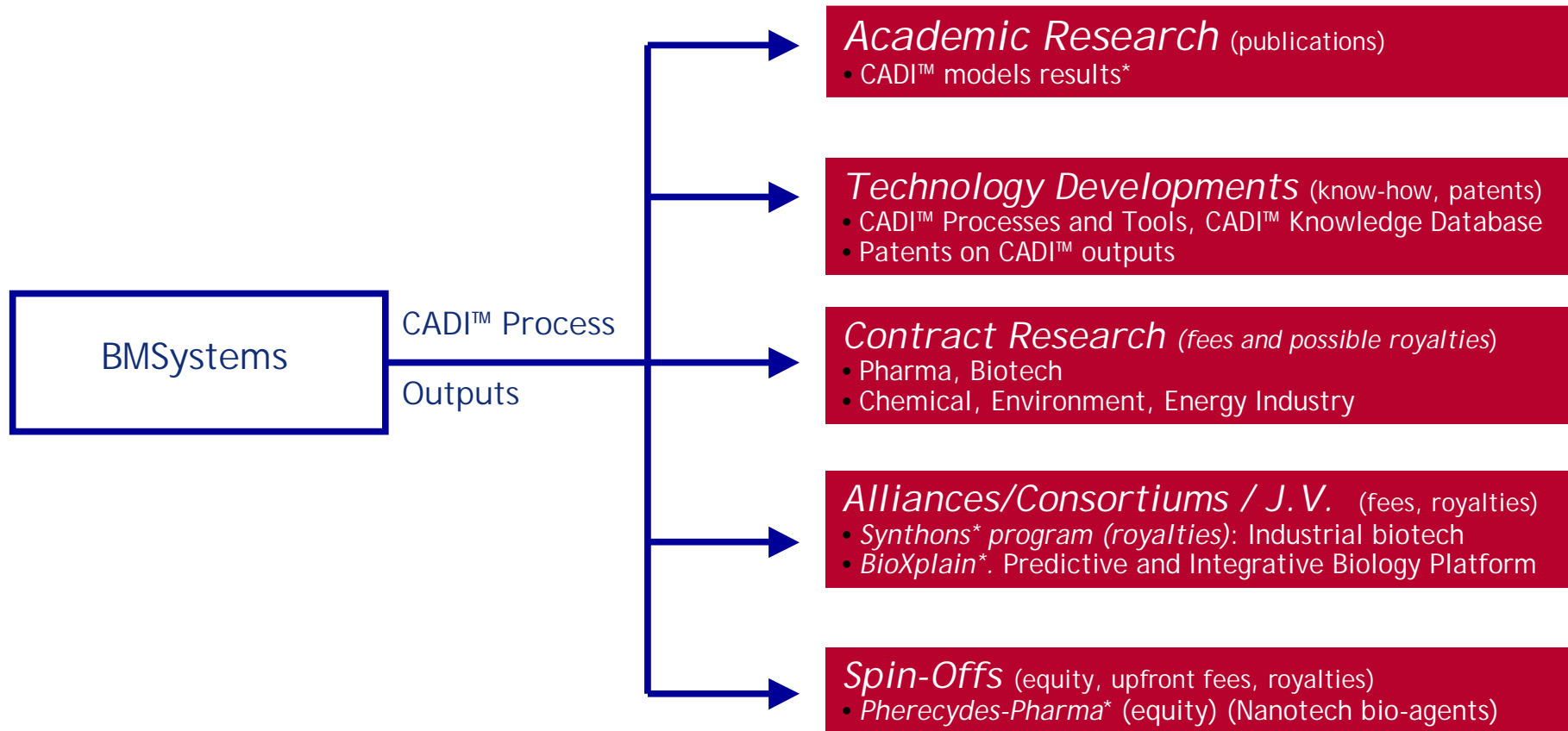

* See the details in the four case studies document



BMSystems programs development

Only non-contractual CADI™ programs extract

Program Name	Validation / Business Partner(s)	Feasib. study	CADI™ vers. 0	Ind. Valid.	Patents / Publi.	First Proof of Concept (POC)	Mid scale or preclinic. P.O.C.	Ready for Business
Nano-Bioagents	Pherecydes							
TAPE	Pherecydes							
Chronic Fatigue Syndrome	Open							
Ebola virus ecology	Open							
Hepatitis C	Open							
CNS-Psychiatry	CEA Life Sciences							
CNS-Neurodegenerative	CEA Life Sciences							
Fibromyalgia	Open							
Pain	Open							
Migraine	Open							
Multiple Sclerosis	Open							
Psychiatric disorders	Open							
Program Synthons	ARD-IBT-L'Oréal							
Program Synthons	ARD-IBT-Rhodia							
Program Synthons	ARD-IBT-Arkema							
Breast cancer-Hras	INSERM							
Tamoxifen resistance	INSERM							
Metastasis mechanism	INSERM							
Müllerian regression	CNRS							
Adipocytes growth control	Open							
Hypercholesteremia	Open							
Metabolic Syndrome	Open							

Infection-Immunology	Oncology
CNS-PNS	Tissue Differentiation
Industrial biotech	Metabolism

1	BMSystems at a glance
2	CADI™ rational

The Life-modeling issue

If you dream to create the first operational bird model...



... a “basic” living Complex system that not only flies...

Be sure to use the appropriate modeling concepts & tools. If not...



...you get a Complicated “Cartesian” system. It does fly, but...

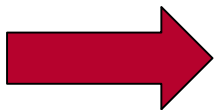

The challenge is clearly not a question of technologies only

Mechanisms of life are not “Cartesian” :

In living cells and tissues numerous components simultaneously interact with multiple partners.

Numerous interaction complexes produce multiple concurrent events.

The biological effects result from the differential integration of ALL these events.

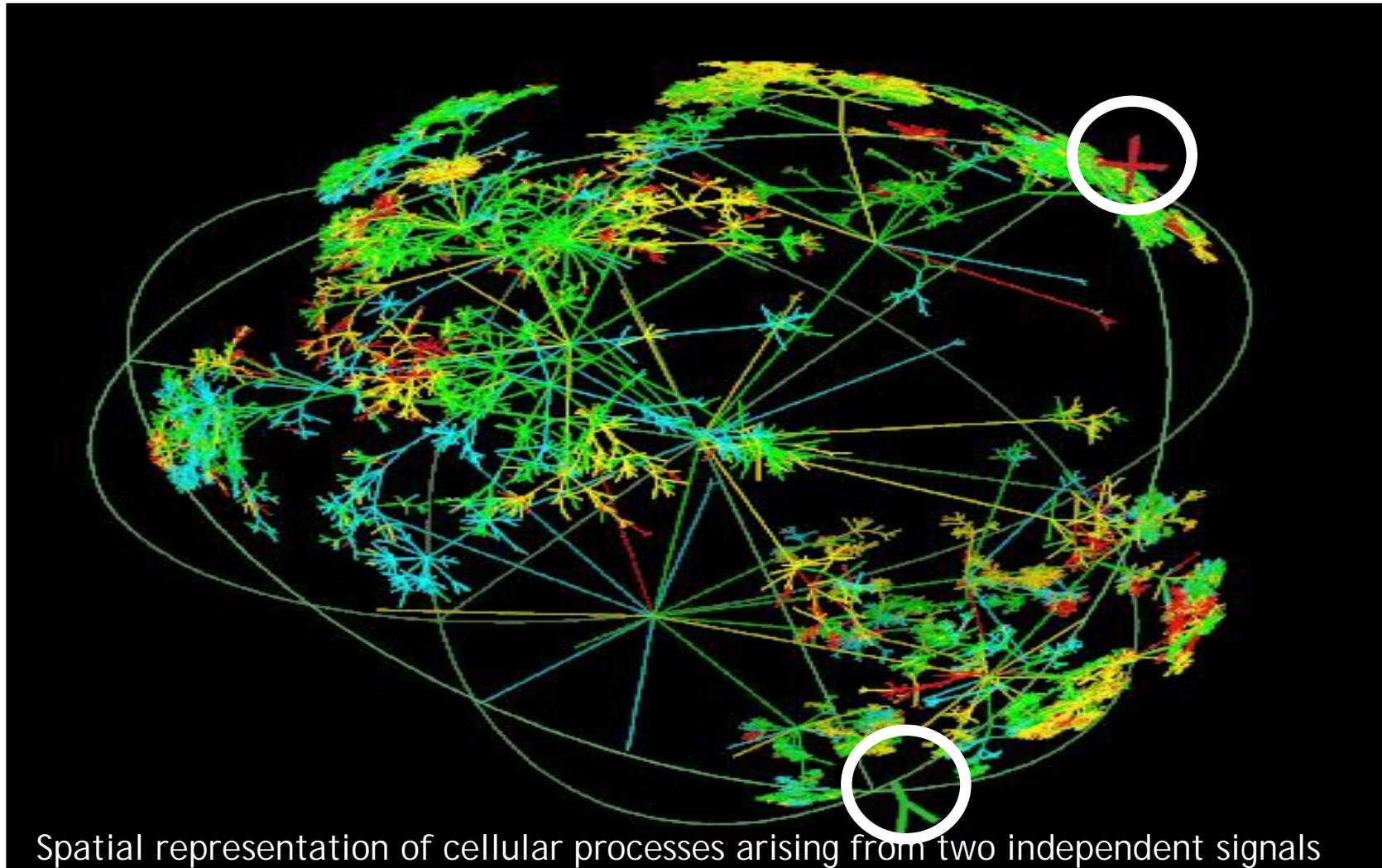

But, "Cartesian" tools are very useful...

"Cartesian" Bioinformatics and Mathematical classical tools have proven to be efficient tools to collect, structure, analyze, simulate specific functions, and to test or to validate innovative hypotheses.

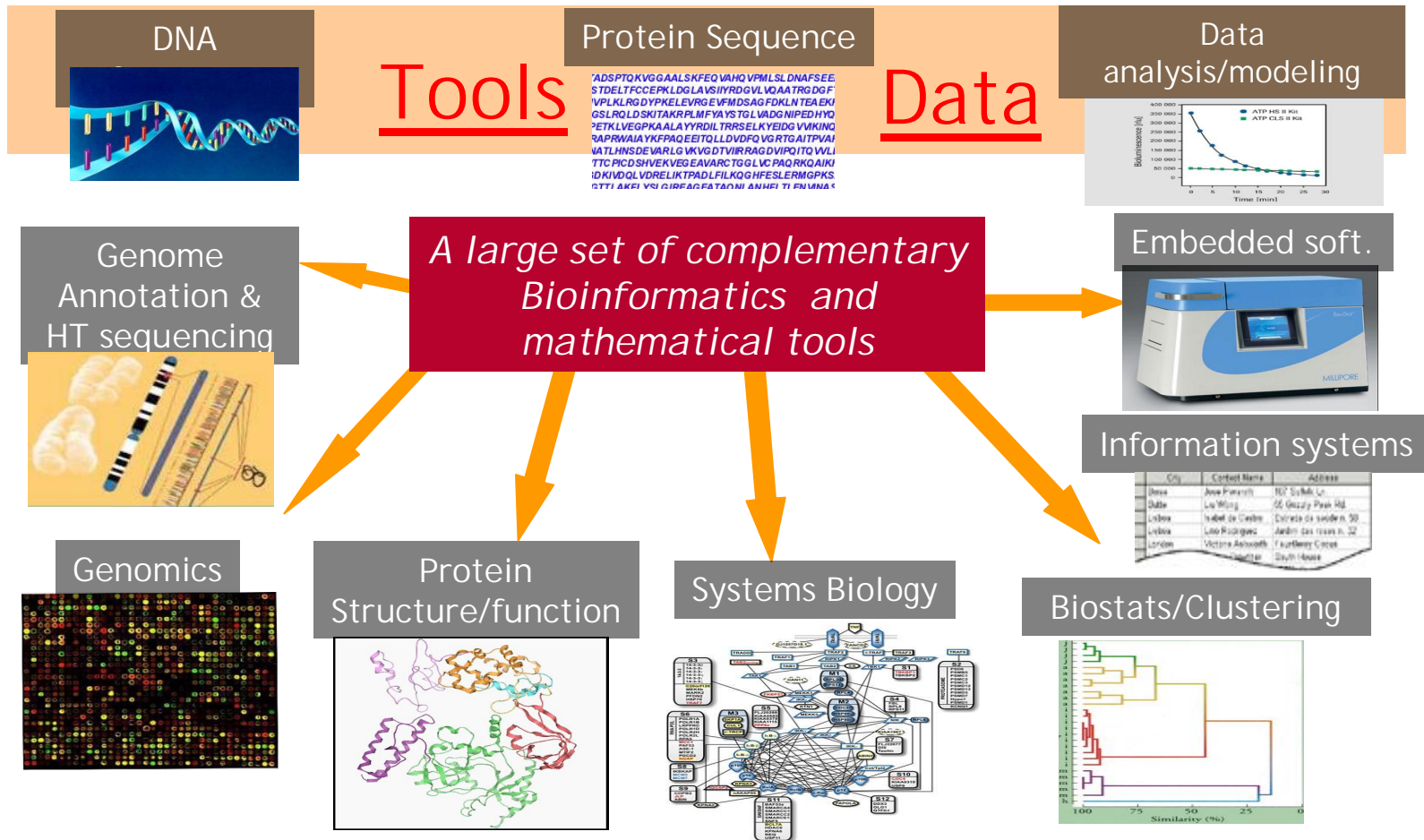

Source: BioXpr

The Life science modeling dilemma

1. The mechanisms of life are *complex non-linear and integrative processes*.
2. In “living complex” systems, *the functions of biological components and mechanisms are event and context-dependent*. The same components/networks can produce different biological effects.
3. *Classical “Cartesian” modeling concepts & approaches*, valid for the majority of man-made artifacts, imply the concept of a “blue-print”. Components are “function-specific” and their assembly pattern determines the final function of the structure they constitute. *But this concept is at the opposite of biological reality...*
4. ... But, “Cartesian” Bioinformatics and Mathematical tools ***have proven to be efficient tools to collect, structure, analyze, simulate specific functions, etc... to test or to validate innovative hypotheses to be generated.***
5. And, *the “garbage in, garbage out”* reality, tells us that the information produced and published (even in top leading publications) *is necessarily ALWAYS incomplete, biased and erroneous to an unknown extents.*

Despite increasing investments in Technology and I.T., the major drugs and biological products submissions to FDA are constantly declining.



We need to change our point of view.

CADI™ Concept Genesis

CADI™ invention: The result of a continuous conceptual & technological innovation process started in the 90s.

- 1989 -1993 Dr. Iris is Group Leader at the CEPH in Paris a Research Institute founded and lead by Nobel laureate Prof. Jean Dausset. He identifies *the lack of appropriate methodologies and tools* to analyze data produced.
- 1993 -1996 Dr. Iris creates & leads Millennium Pharmaceuticals' (USA) HT Sequencing Unit. *He invents & develops basic tools and methods* required for Integrative Biology.
- 1996-2001 - Dr. Iris is co-founder and C.S.O. of ValiGen SA in Paris
 - He invents and develops the computerized data gathering, data mining, clustering and integration tools & technologies with Lion BioScience *through a major European "Eureka" program granted 18.6 M Euros.*
 - He finalizes the Bio-Graph™ analytical platform based on the "Cartesian positive selection" concept and is one of the first to *identify and understand the limitations* of this kind of platform if used alone.
- 1999-2001 - Following his understanding of the Eureka program failure, *Dr. Iris decides to abandon the Bio-Graph™ type platforms* and starts working on a new Generation of analytical platform (CADI™) based on the "negative selection" concept.
- 2002-2003 - Dr. Iris with M. Gea, P-H Lampe, P. Santamaria and Dr. Dine *initiate the BMSystems project* and develop CADI™ tools and methodologies.
- 2004 - *The company is created and signs its first business deal with a Pharma.*

The 5 CADI™ principles

1. An *“Architectural Principles”* Approach.
2. Our *“Negative Selection”* Process.
3. Our *“4 steps validation”* Process.
4. Our *“Broad life sciences & IT”* Expertise.
5. Our *“synergic collaboration”* with classical IT partners.

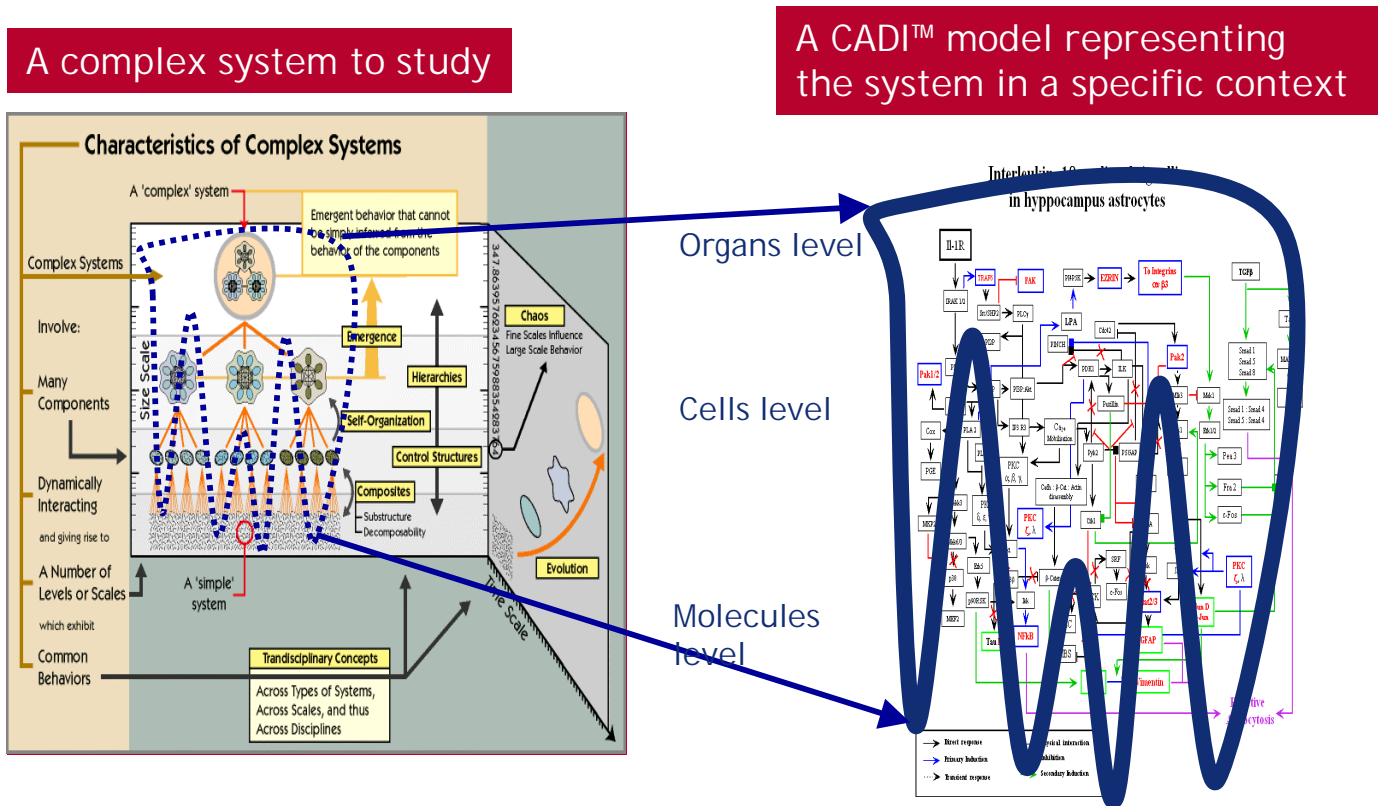



CADI™ “ Architectural” Principles

The efficient and reliable construction of innovative buildings.

- *The design phase*: Architects conceive and design the building so that it obeys defined functional and structural specifications while integrating within a given environment.
- *The “blueprint” design phase*: The resulting plans are then forwarded to engineering specialists who calculate and/or test components parameters where and as required.

The resulting final blueprint is then forwarded to the contractors who then build the structure according to the blueprint specifications.

- In this analogy, *BMSystems acts as the “Architect”* while mathematical modelers and experimentalists play the complementary role of “engineering specialists”.
- As with traditional architecture, the results must be solid, useful, convenient and *have intrinsic elegance*.

By keeping to the architect's point of view and overall design attitude, BMSystems' scientists are able to succeed and solve unusual problems where traditional methods fail.

CADI™ negative selection process

The first operational application of the negative selection concept

CADI™ original concept is an operative answer to “the garbage in garbage out issue”, and a disruptive innovative way to generate new knowledge from new cross supported hypotheses

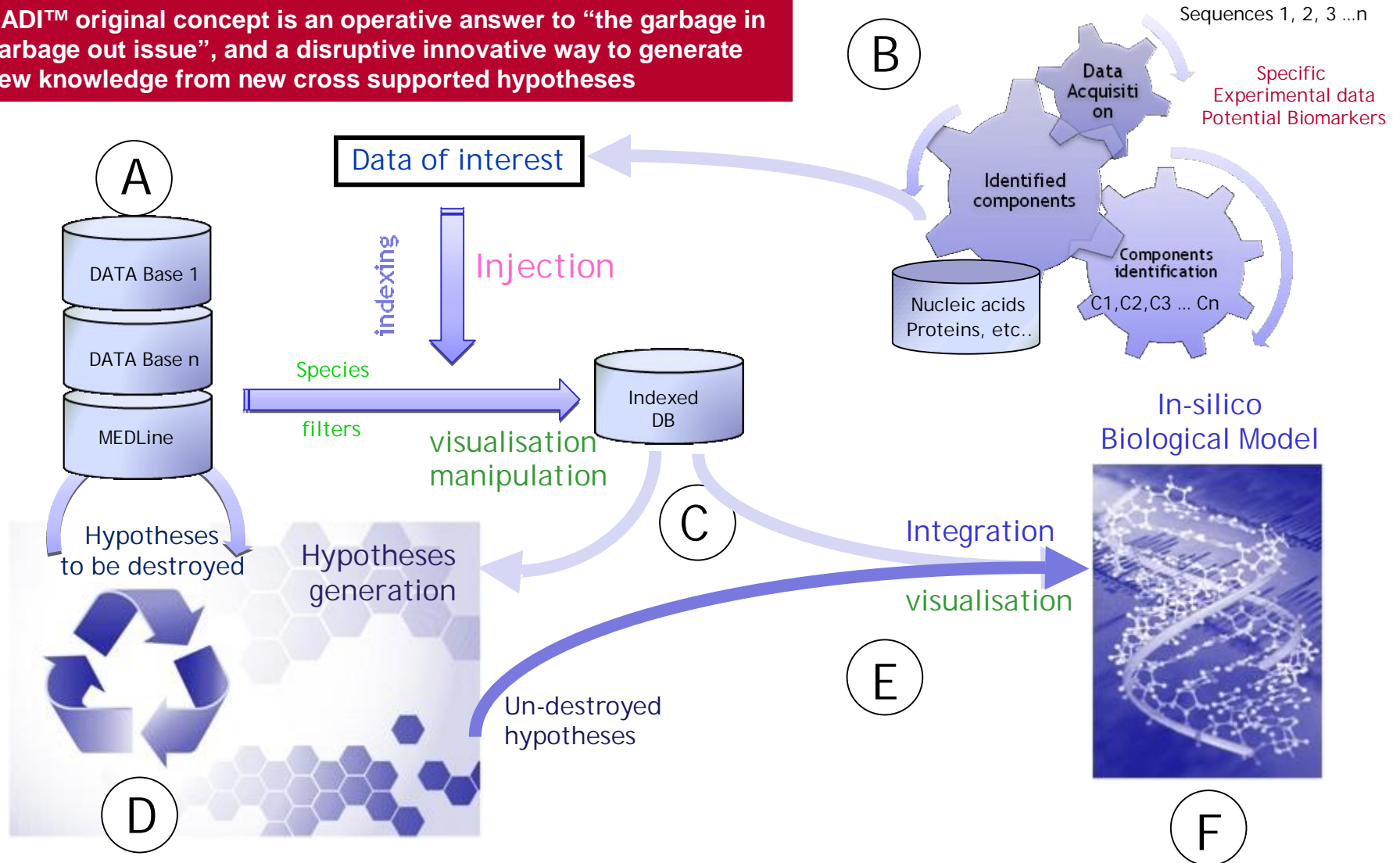

CADI™ 4 steps validation process

➤ The CADI™ 4 steps validation process starts when the integrative biology researchers generate the initial CADI™ model, following the steps from 1 to 4:

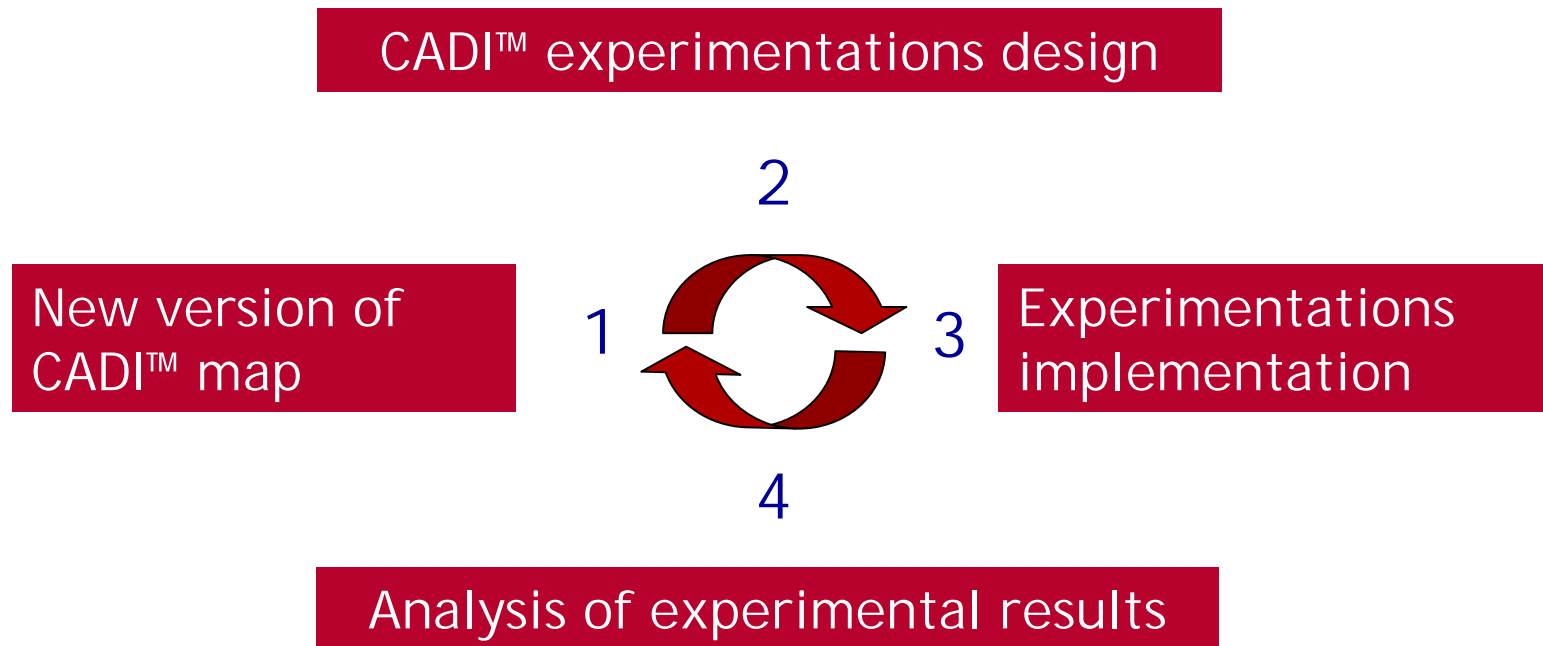

➤ The CADI™ 4 steps validation process stops when no key unexpected results are reported.



Now we can !



BMSystems “ Broad life sciences & IT” Expertise

A strong multidisciplinary & experienced founders team

- *Dr. François Iris (PhD) : Chairman, CSO-CTO. Geneticist, physiologist & molecular biologist.*

Creator of Millennium Pharmaceuticals' (USA) high-throughput DNA sequencing unit. Former collaborator of Nobel Laureate Prof. Jean Dausset. Inventor of new technologies in molecular biology. MRC Overseas fellow, Member of H.U.G.O., Wellcome Trust Systems Biology experts board. Member of the Cambridge Healthtech Institute Scientific Committee, Member of the Evaluation committee for the funding priorities in the “Medical Systems Biology- MedSys” program; German Federal ministry of Research. 14 original articles in international journals including Nature, Cell, Nature Genetics, Genomics, J Mol Endocrinol, J Comp Biochem Physiol. 7 international patents, 3 patent applications currently undergoing examination, 5 book chapters, numerous invited communications at international conferences.

- *Manuel Gea: C.E.O & VP R&D Information Systems. Information systems specialist:*

- Scientific Engineering Degree from Ecole Centrale Paris, Chairman of the Supervisory board of PHERECYDES PHARMA (anti-bacterial bio-agents pharmaceutical company); Former CEO Hemispherx Biopharma Europe. Founder and President of Centrale-Santé. Founding-Administrator of the computing firm Formitel. Former McKinsey executive, creator of Practice Pharma services in France. Former Division Managing Director with Boehringer-Ingelheim France. Former International business manager Colgate-Palmolive Company (US), Co-founder and Vice President of the Biotech Committee of the Association of the Pharma companies operating France (LEEM). Member of the executive board of Medicen Santé, the world-class bio-cluster of Paris region. Vice-President AdebioTech Committee. Co-founder and Evaluation Committee member of Paris Biotech (leading biotech incubator).

- *Gérard Dine (MD, PhD): Chief Medical Officer: Physician, biologist:*

- Head of the Haematology Dept. at Troye's hospital. Founding member and Head of the Biotechnology Dept. at Ecole Centrale Paris. Founding-President of Troye's Institute of Biotechnologies. Former President of the Institute for Sports Medicine.

- *Paul-Henri Lampe: CIO & Systems Integration Director. Systems Integration specialist* Scientific Engineering Degree from Ecole Centrale Lille. Master Degree in Applied Mathematics from Ecole Centrale Paris. Former IBM Systems Integration Manager. Former Information Systems projects manager in an Acute Care Hospital in Paris.

- *Pablo Santamaria: IT & Internet Systems Director. Internet technologies specialist:* Scientific Degree from Ecole Centrale Paris, Founder and President of the computing firm Formitel (1988) .Founding President of the Centrale-Ethics Think-Tank. Vice-President of Centrale Human Resources Professional group. Former Senior Consultant Information Systems Evaluation (INSEP). Former Industrial Maintenance Manager at Glaxo Pharma (Evreux, France)



Synergic Collaboration with complementary IT partners through BioXplain

Let's go a step beyond with partners. The pharmaceutical industry now requires its *scientists and clinicians* to harness & explain the mechanisms of health and diseases.

But they need *adapted systems and tools to help them work*.

Three complementary, cutting edge life sciences companies decided to collaborate to address this challenge:

- *Bio-Modeling Systems*: The inventor of CADI™ methodologies and tools, including the collaborative iterative validation process.
- *BioXpr*: The most diversified provider of Software solutions built from a versatile library of modules to create real-added value from "OMICS" datasets.
- *Kayentis*: The provider of the first "Digital Pen and Paper technology 2.0", the universal platform delivering "contextualized" information .





BioXplain: The first Open Platform
for Iterative Predictive and Integrative Systems Biology.



BioXplain founders

Three founders sharing same values and history

Company	Company specificities	Company information
	<ul style="list-style-type: none"> • Created by senior scientists and engineers. • Inventor of CADI™ methodologies and tools • Research-based biotech company • <i>The company does not sell its technologies nor access to its technologies</i> • 1 spin-off Pherecydes-Pharma 	<ul style="list-style-type: none"> • The R&D booster for life sciences discoveries, Member of BiO • Established : 2004 • 9 FTE based in France, 100 people working on BMSystems research programs • Active in the pharma, Industrial biotech, energy and biosecurity businesses
	<ul style="list-style-type: none"> • Created by senior scientists and biologists. • Collect, format, store, integrate, analyze and interpret from literature and experimental data ("OMICS", "environmental" data ,...) • Technology based on a library of powerful software modules that can be easily combined to create specific custom tools. 	<ul style="list-style-type: none"> • A State of the Arts software solutions company. • Established 2003. • 10 people based in Namur Belgium. • Namur University Spin-off. • Numerous clients in the pharma, red and green biotech industries.
	<ul style="list-style-type: none"> • Created by senior scientists and clinicians • Collect, carry and share research, pre-clinical, clinical and post-marketing data using Digital Pen and Paper technology, DPP. • Full, un-biased and complete data capture in real-time ensure the completeness and integrity of the data. 	<ul style="list-style-type: none"> • A software provider with strong growth • Established in 2004. • 40 staff based in France (Gif-sur-Yvette, Grenoble, Reims) and in the United States (Philadelphia). • More than 10 000 users in 44 countries on 5 continents.



BMSystems' Business Description

Our Business Proposal specificities

CADI™ outputs for a specific research program:

- *The CADI™ presentation and maps:* The interactions maps describe *the contextualized inter and intra cellular relations within & between pathways.*
- *The CADI™ report:* The report (management summary and full report) explains and supports the CADI™ interactions maps.
- The CADI™ outputs are available for protection/patent filing by the client during a negotiated exclusivity period of time.

BMSystems does not sell:

- Its CADI™ technologies and methodologies (All the means to achieve the CADI™ outputs).
- The access to its CADI™ technologies and methodologies.
- Its CADI™ knowledge Databases and its proprietary pathways.

CADI™ Proprietary Technologies and Know-how:

- CADI™ Search (data acquisition & mining);
- CADI™ Framework (data organisation & structuring);
- CADI™ Fiber-N (integrative engine);
- CADI View (model representation & visualisation).
- CADI™ knowledge Database;
- BioXplain, the First Open Platform for Iterative, Predictive and Integrative Systems Biology

Our Business deals structure

The three key Phases of CADI™ programs:

- *Feasibility Phase:* Feasibility study if necessary to define possible success chances of proposed programs (clients, partners or internal to BMSystems).
- *CADI™ Phase I:* Construction of the CADI™ model version “0” with non-confidential information and proprietary CADI™ Knowledge database information.
- *CADI™ Phase II:* Independent Experts and Experimental 4 steps validation process of the CADI™ model forecasts. The Phase II is the *indispensable collaborative phase* to secure and maximize industrial exploitation of the CADI™ model. The CADI™ outputs are available for protection/patent filing by the client during a negotiated exclusivity period of time..

Attractiveness of our business deals for our clients:

- Very low client’s human resources investment *but with a necessary strong motivation and involvement of its people.*
- *A unique opportunity to train client’s team members* to integrative biology
- No necessary large scale technology transfer.
- *No large upfront investments* compared to classical systems biology programs.
- During the research program phases, the client benefits of BMSystems exclusivity.
- *Very flexible deal structures.* *One shot or “post program exclusivity”,* but the decision must be taken before the launch of the Phase I Program. The additional costs are a percentage of total phase costs, and recurrent cost per year for post program exclusivity period.
- To confirm the “*post program exclusivity*”, the Phase II program must have been launched.
- Possible/recommended after sale follow-up program.
- Finally, *the creation of significant value through savings of time and money*

BMSystems in the world

A strong International Scientific exposure

International Scientific conferences participations as speaker

- 2009: Brussels Belgium, 20-21 October: BE Live IT - Neurodegenerative Collaborative program presentation
- 2009: Houston USA: May 3-7 2009: 12th NSTI Nanotech conference. Innovative Phages Applications
- 2009: Manchester UK. February 26-27: 4th Annual Biomarkers Congress
- 2008: London UK. December 15-16, 2008: 1st Annual CNS Drug Development Conference. Maximizing new developments for neurological diseases
- 2008: Brussels Belgium, 30-31 October: BE Live IT - Biomarkers in medical biotech discovery
- 2008: Brussels Belgium, 30-31 October: BE Live IT - industrial biotech session Synthons platform with ARD*
- 2008: Brussels Belgium, 16-17 September: European Forum for industrial Biotech organized by Europabio: Synthons platform presentation with our partner A.R.D.*
- 2008: Edinburgh Scotland U.K., July 26-29: International Phage Conference**
- 2008: Atlanta Georgia USA, June 23-25, 2008: 12th Biodetection Technologies conference**
- 2008: Manchester U.K. May 14-15, 2008: 3rd Annual Biomarkers Congress
- 2007: London U.K. March 12-15 , 2007: Drug Discovery Technologies
- 2007: Munich Germany January 23: Integrative Biology conference Max Planck Institute
- 2006: San Francisco California USA, June 19-21, 2006: Beyond Genome
- 2006: London U.K. March 13-16 , 2006: Drug Discovery Technologies
- 2005: Orlando Florida USA, December 9, 2005: Metabolic profiling conference
- 2005: London U.K., March 16, 2005: Pharma Solutions Conference
- 2003: Ottawa Canada, November 17, 2003: BioNorth conference

BMSystems expertise recognition

*Prestigious scientific, professional
and evaluation committees memberships*

- Member: Evaluation committee of the funding priorities in the “Medical Systems Biology- MedSys” program; *German Federal ministry of Research*; Berlin (2008-)
- Member: *Scientific Committee of the Cambridge Healthtech Institute* The world leading scientific conferences organizer USA (2005-)
- Member: *Wellcome Trust’s Board of Experts*, Systems Biology. The world's largest medical research charity funding research programs into human and animal health U. K. (2001-)
- Elected Member: *Human Genome Organization (HUGO)*; (USA) (1994-)
- Overseas Fellow: *Medical Research Council (MRC)*; U.K. (1989-)
- Member: *Biotechnology Industry Organization (BIO) USA* (2008-)
- Member: Executive *committee Medicen Paris Region* (2004-)

BMSystems' efficacy

Proof through published achievements

CADI™ Models published in prestigious peer-reviewed journals

- 2009, TISSUE DIFFERENTIATION: *Médecine & Sciences*: Müllerian duct regression explanation. Integrative systems biology & experimental Biology. Publication with CNRS experimental data.
- 2005, CANCER: *Journal of molecular Endocrinology*: Integrative analysis of gene expression patterns predicts specific modulations of defined cell functions by estrogen and Tamoxifen in MCF7 breast cancer cells. Publication in collaboration with INSERM unit 553.
- 2003, CANCER: *Nucleic Acids Research*: Integrated transcriptome analysis of the cellular mechanisms associated with Ha-ras-dependent malignant transformation of the human breast epithelial MCF7 cell line. Publication in collaboration with INSERM unit 553. *World first. First in-silico model of a complex human disease validated in-vitro and published*

Collaboration to scientific reference books:

- 2008, CNS: *Biomarkers for Psychiatric Disorders*. (Ref. ISBN: 978-0-387-79250-7, November 2008). Dr. François Iris, is the author of the Integrative Biology chapter of the book. The editor, Prof. Christoph W. Turck, is head of the Proteomics and Biomarkers branch at the *Max Planck Institute for Psychiatry*
- 2008, CNS: *Integrative Biology in the discovery of relevant biomarkers monitoring cognitive disorders pathogenesis and progression*. *BioTribune Springer publisher* Vol. 28, august 2008.
- 2005, Systems Biology: *Computer-Assisted Integration into Biological Pathways of Modulated Gene Expressions Patterns*. In « *Bioinformatics: New Research* », Yan PV editor, Chapter IV, pp 81-100; *Nova Publishers* (ISBN: 1-59454-242-2; 2005)

BMSystems' 4 case studies

The Proof through operational achievements

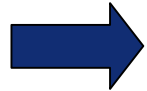

New therapeutic strategy: Publication, in 2003, with the INSERM unit 553, of the first independently validated in-silico model of a complex human disease.



Spin-Off: 3 patented new disruptive technologies & successful launch and financing of Pherecydes-Pharma, the first bio-defence and bio-security company in France to efficiently & reliably address first bacterial threats, next viruses, and then toxin threats.

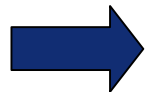

Consortium: Co-founder in 2006, as integrative biology partner, with its key partners A.R.D., I.B.T. and C.V.G., of the Synthons platform, the major integrated collaborative industrial biotech platform in France,

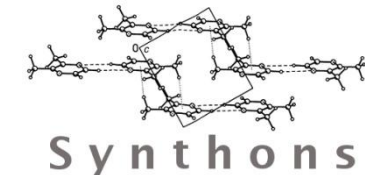

Industry Award & patent : This collaborative work received a Bio-IT World 2009 Best Practice Award. A second CADI™ modeling program with the same CEA-SEPIA* research team also allowed the discovery of novel therapeutic approaches in the treatment of poorly served CNS diseases (patent filed).



BioXplain

*The Alliance for Integrative Systems Biology
The First Open Platform for Iterative, Predictive and
Integrative Systems Biology*

BMSystems enlarges its services proposal to allow the pharmaceutical industry's scientists and clinicians to harness existing models using classical "user friendly" & adapted tools to help them work.

Alliance: Co-founder in 2009 of BioXplain, the First Open Platform for Iterative, Predictive and Integrative Biology, with BioXpr and Kayentis complementary, cutting edge life sciences companies that decided to collaborate to address this challenge.

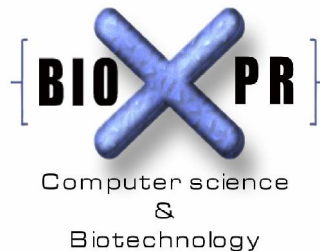

BioXplain 2010



BioXpr: The Integrative Software & Services Platform

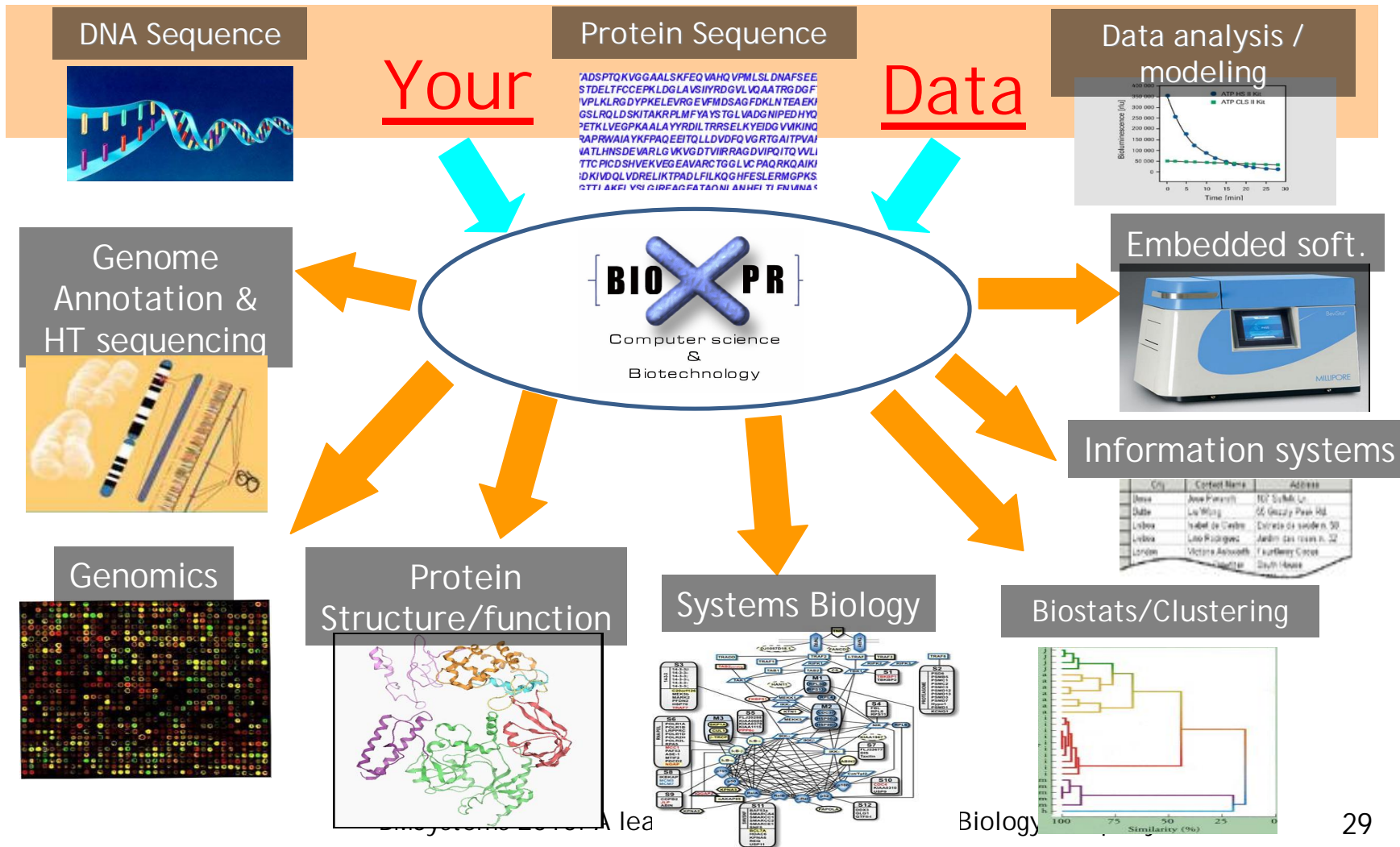
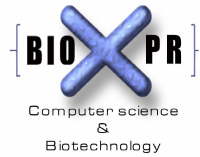

The «Digital Pen and Paper 2.0» universal solution platform



*45 countries, 5 continents, 10 000 users
3 Millions pages captured from pharma,
hospitals, Research centers , patients ...*

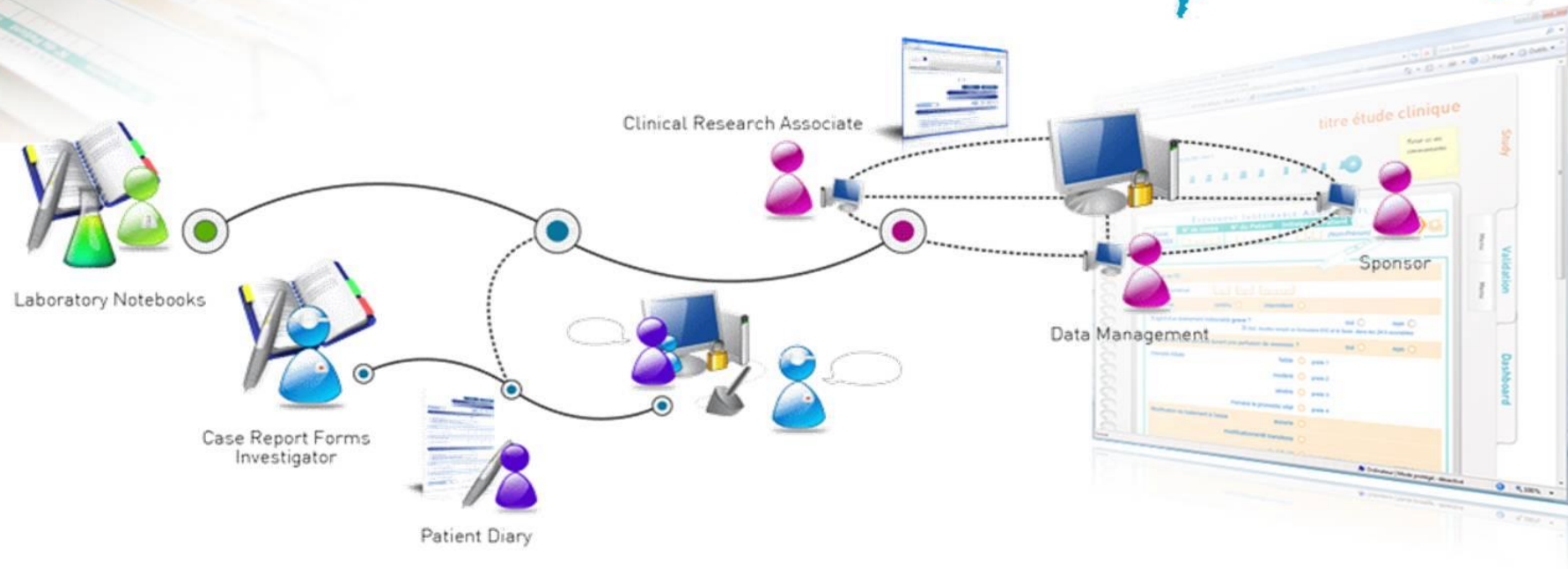



Clients & Partners of BioXplain founders

Diversified complementary network



Comparative R&D Program value generation

BMSystems: a leading Integrative Systems Biology Company

New validated knowledge

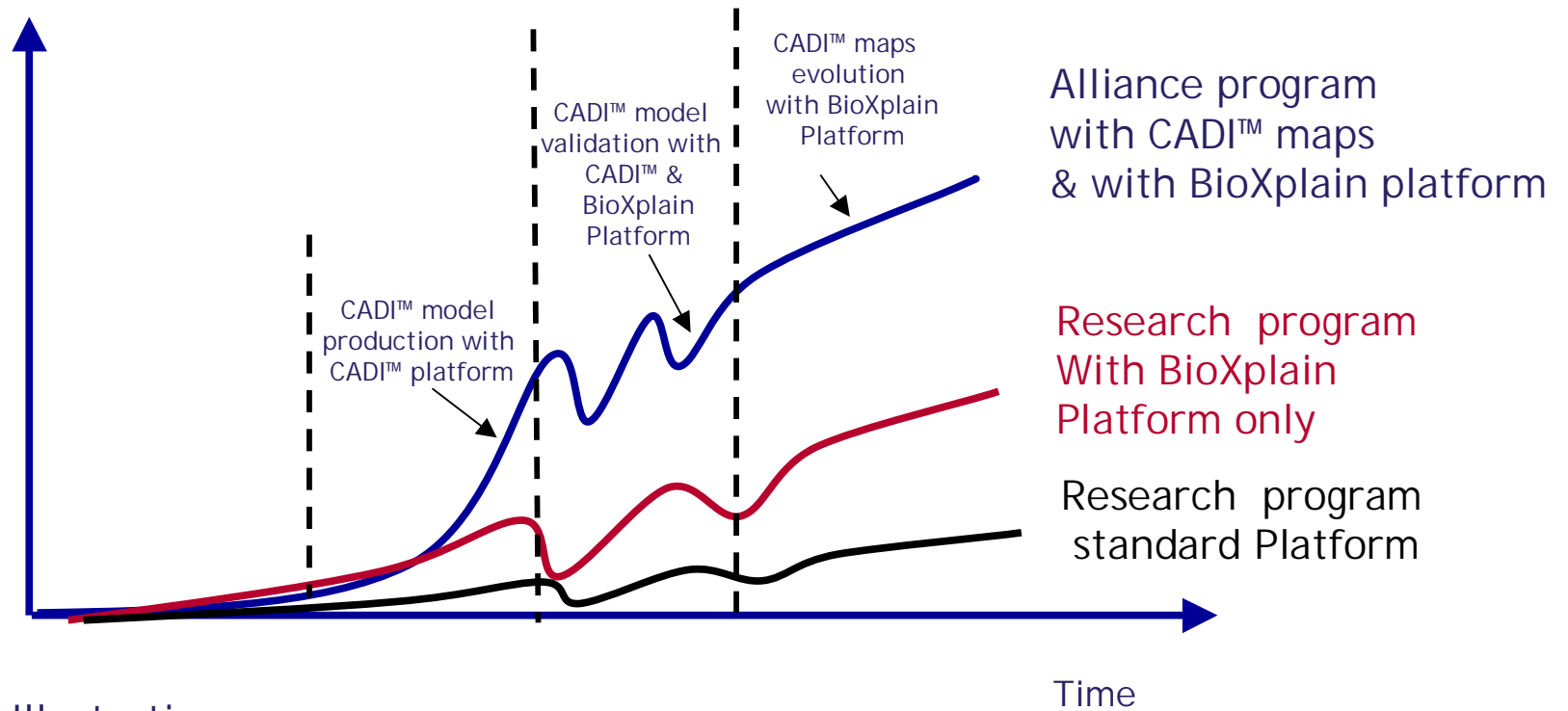

Illustrative

www.bmsystems.net ; manuel.gea@bmsystems.net